



OUNDLE

School

2020 Academic Scholarship
Preliminary Examination

Mathematics

Time Allowed: 90 minutes

Total Marks: 85

Instructions

- Calculators may NOT be used.
- Write your answers on **lined paper** and **show as much working as possible**. **Answers without clear logical working will gain little credit.**
- Do not spend too long on any single question. If you are having difficulty with a particular question, move on and return to it at the end if you have time. Do not be concerned if you cannot answer all of the questions.
- **Please note that the diagrams in Question 13, 14 and 15 have not been drawn accurately or to scale.**
- **At the end of the examination**, hand in both the question paper and your answers with your name clearly indicated on all sheets.

1. Work out :

(a) $74 + 19$

(b) $-13 - (-17)$

(c) $8 \times \frac{2}{3}$

(d) $8 \div \frac{2}{3}$

(e) $2\,000 \times 0.0005$

(f) $0.4 \div 0.08$

(g) $1\frac{3}{4} + 1\frac{1}{3}$

(h) $12 - 4 \div \frac{1}{2} + 6 \div (1 - 4)$

(i) 10 % of 30 % of 3 000

(j) $\sqrt[3]{8}$

(k) $\sqrt[3]{8\,000\,000}$

(l) $\sqrt{6^2 + 8^2}$

(m) 3×2^0

(n) $(3 \times 2)^0$

(17 marks)

2. If $d = 2$, $e = -3$ and $f = \frac{-1}{4}$, find the values of :

(a) $d - e + f$

(b) $\frac{d \times e}{f}$

(c) $2def$

(d) $\frac{d^2}{f^2}$

(e) $(ef)^d$ (10 marks)

3. Rewrite each of the following, inserting the correct signs (out of +, -, ×, ÷) in the boxes to make the statement true :

(a) $\frac{2}{3} \square 1.5 = \frac{4}{9}$

(b) $\frac{3}{4} \square 3 = 2\frac{1}{4}$

(c) $\frac{3}{8} \square \frac{3}{4} \square \left(\frac{1}{12} \square \frac{1}{4} \right) = \frac{1}{6}$ (4 marks)

4. Find the next two terms in each of the following sequences :

(a) 8, 2, -4, -10,,

(b) 20, 10, 5, 2.5,,

(c) 1, 4, 9, 16,,

(d) -1, 2, 1, 3, 4, 7,,

(e) $\frac{2}{7}, \frac{3}{14}, \frac{5}{21}, \frac{7}{28}, \dots, \dots$ (8 marks)

5. Find the fraction that is halfway between

(a) $\frac{1}{5}$ and $\frac{1}{6}$ (please note : the numerator and denominator of your answer must both be whole numbers)

(b) $\frac{1}{a}$ and $\frac{1}{b}$ (4 marks)

6. Remove brackets and simplify :

(a) $2(5 - x)$

(b) $3x(x + 3) - (1 - x)$

(c) $(4x + 1)^2$ (5 marks)

7. Factorise fully :

(a) $8y - 16$

(b) $xy^2 - 2xy$

(c) $8y - 16 + xy^2 - 2xy$ (4 marks)

8. Solve each equation for x :

(USE A CLEAR ALGEBRAIC METHOD – NOT TRIAL AND ERROR – SHOWING YOUR WORKING IN FULL)

(a) $6x + 1 = -2$

(b) $5 - 2(x + 3) = 4 - x$

(c) $4 - \frac{x}{3} = \frac{7}{2}$

(d) $\frac{9x+2}{9x-2} = 2$ (8 marks)

FOR THE REMAINING QUESTIONS, YOU CAN ANSWER THEM IN ANY ORDER THAT YOU CHOOSE. YOU MUST SHOW FULL WORKING TO MAKE IT CLEAR HOW YOU OBTAINED YOUR ANSWER. (ANSWERS WITHOUT WORKING WILL BE AWARDED VERY FEW MARKS).

9. John takes 40 minutes to walk to school and then to run home. When he runs both ways, it takes him 24 minutes. He has one constant speed whenever he walks, and another constant speed whenever he runs. How long would it take him to walk both ways ?

(3 marks)

10. You are told that $x^2 - y^2 = (x + y)(x - y)$

Use the above result (and NOT long multiplication) to find the value of :

(a) $45^2 - 15^2$

(b) $736^2 - 264^2$

(c) $1\,007 \times 993$

(3 marks)

11. Asif is shopping for a new outfit for a special occasion. He needs a shirt, a pair of trousers and a pair of shoes. Once he has picked out the items that he likes and checked the prices, he realises that :

If he doesn't buy the shirt, he can get the other items for £115

If he doesn't buy the trousers, he can get the other items for £100

If he doesn't buy the shoes, he can get the other items for £75

But, of course, he needs the shirt, the trousers and the shoes. So how much will he have to pay for all of them ?

(PLEASE NOTE : A 'TRIAL AND ERROR' APPROACH IS UNLIKELY TO SUCCEED IN THIS QUESTION AND WILL BE AWARDED VERY FEW MARKS).

(3 marks)

12. In a bag, there are 180 marbles, of which n are red and the others green. A marble is to be drawn randomly from the bag. If 10 more red marbles were added to the bag, the probability of drawing a red would be doubled.

Write down and solve an equation in n to work out how many red marbles were originally in the bag.

(PLEASE NOTE : A 'TRIAL AND ERROR' APPROACH TO THIS QUESTION WILL BE AWARDED NO MARKS)

(4 marks)

13. A solid cuboid is shown below, with dimensions 3 cm by 5 cm by 6 cm. A spider which is at point *S* needs to crawl on the **outside** of the cuboid to get to a fly which is at point *F*. Assuming that the fly does not move, work out the shortest distance that the spider can travel to reach the fly.

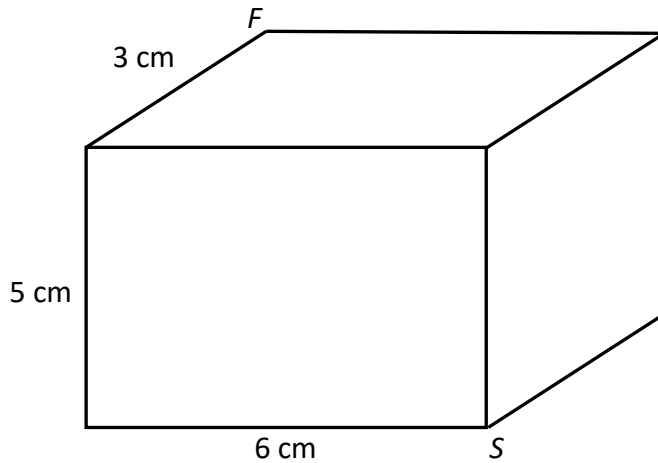

Diagram NOT drawn to scale.

(3 marks)

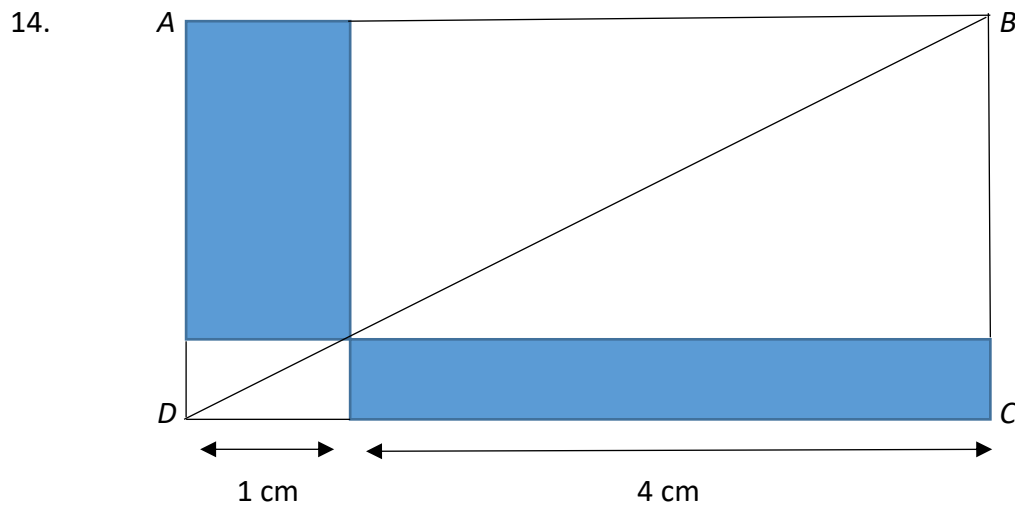

Diagram NOT drawn to scale.

Express the area which is shaded in the diagram as a fraction of the whole rectangle *ABCD*. Measurements have been made of the length of the rectangle but not the width.

(4 marks)

15.

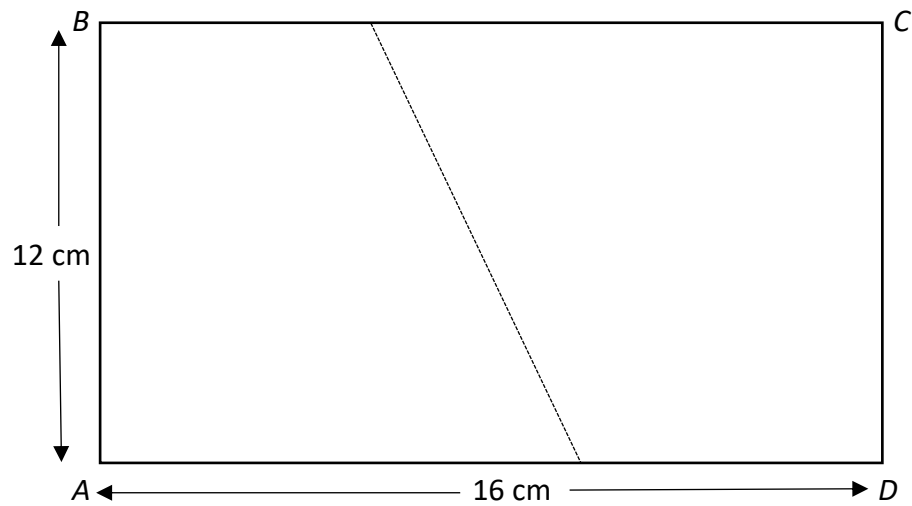

Diagram NOT drawn to scale.

A rectangular piece of card $ABCD$ has $AB = 12$ cm and $AD = 16$ cm.
If the card is folded so that C is on top of A , how long is the crease?

(5 marks)

END OF EXAMINATION